

FZ 钢球保持架

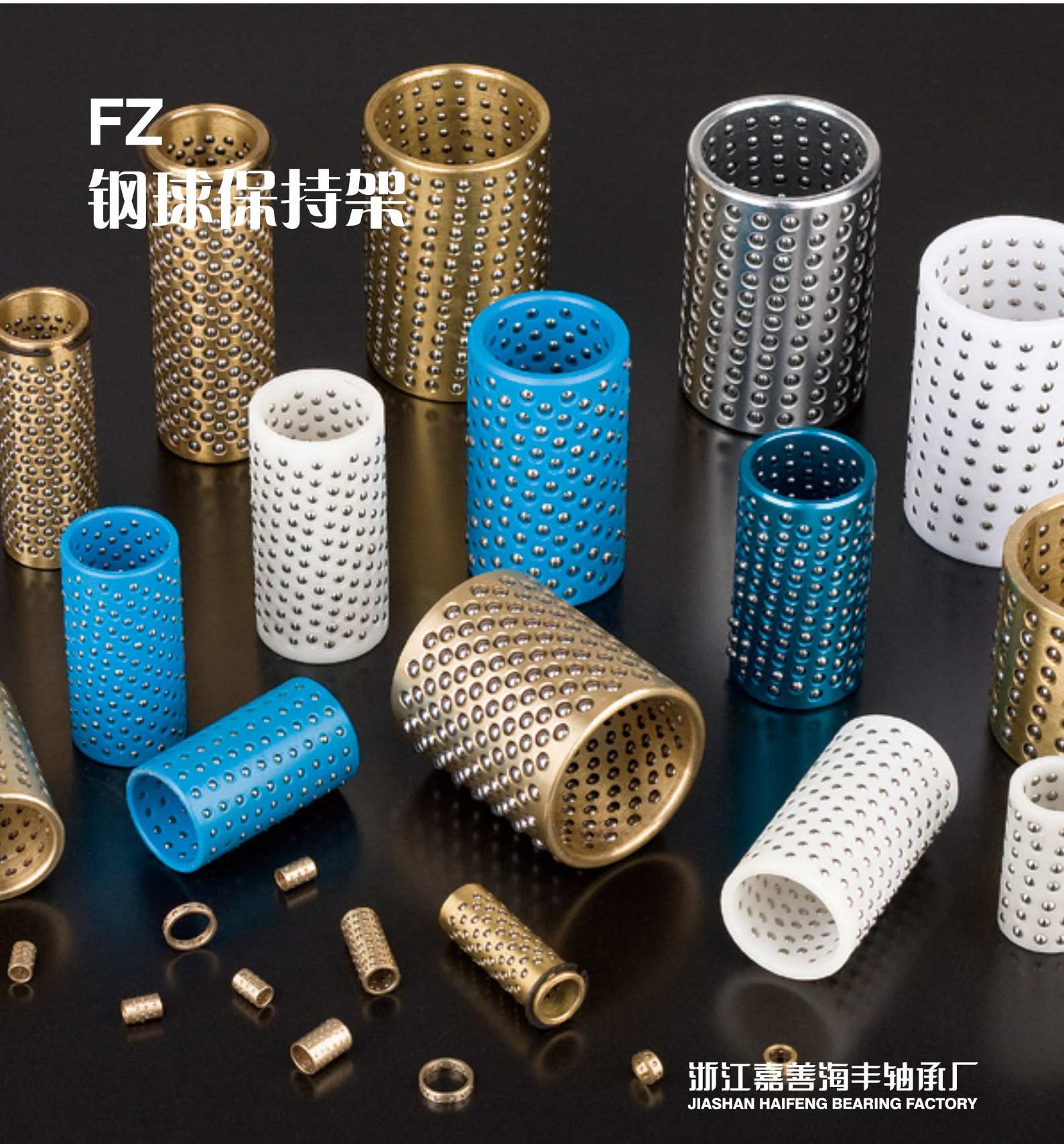



公司简介

INTRODUCTION

嘉善海丰轴承厂（HFB）是一家专业从事轴承设计生产的实体企业，位于浙江嘉善县，地处长三角都市经济圈，与上海、苏州、杭州接壤，地理位置优越，交通便利。

公司生产的产品主要产品SF-1系列无油润滑轴承，SF-2系列边界润滑轴承，FZ系列钢球保持架，JDB系列固体润滑轴承，JF系列双金属轴承，FB系列青铜卷制轴承系列等多个系列产品。

产品广泛应用于冶金、汽车、矿山、石油、化工、电机电器、船舶、印刷、机械、水利、模具、铁路机车等领域。

欢迎广大海内外客户与我们洽谈业务，我们将竭诚为您提供一流的产品，一流的服务。

Jiashan Haifeng bearings Co., Ltd, is specialized in manufacturing sliding bearing. Our main products are: SF-1(DU) self-lubricating bearings, SF-2(DX) boundary self-lubricating bearings, JF bi-metal bearings, JDB cast bronze with solid lubricants bearings, FB090 bronze bearings, FZ ball retainer, FR PTFE tape, FD bronze powder with PTFE tape, FU sintered bronze bearings etc.

We can supply products with stable quality, and has won the trophy and certificate authorities. It is widely used in hydraulic elements, automobile, Metallurgical Mines, Ocean Station Vessel, Industrial Machinery, Petroleum Industry Machinery, Textile machine, lifting appliance, Printing, foods and Construction Machinery etc.

We are committed to supplying products of the highest quality and providing a comprehensive and professional service.



钢球保持架 Retainer bearing

该产品是以铜合金(FZH)、铝合金(FZL)、POM树脂(FZP)为保持架，表面加工有规则的孔穴，在其孔穴中镶嵌入滚动钢球，孔口用油槽圆周锁球工艺。产品被广泛应用冷冲模滚动模架、高精度机床、机床附件，以及高精度轴向或轴径向同时运动场合。

Retainer bearing made copper alloy, hard alloy and POM colophony as holding frame, the surface was processed some well-regulated holes, and embed the rolling steel balls in the holes, orifice used technics of oil groove circle locked ball. The products are widely used in punching machine, die machine, high precision machine which need rotation and vertical motion.

※标准产品标注方式：Standard Bushing Label Mode FZ □ 1950 × 3

单位Unit: mm

| 型号规格 Designation | φD | H | φd | E _N | M _N | Balls | t | T |
|---------------------|----|-----|----|----------------|----------------|-------|------|------|
| FZ □ 1950 | 19 | 50 | 3 | 12 | 8 | 96 | 5.5 | 5.75 |
| FZ □ 1960 | | 60 | | | 10 | 120 | | 5.25 |
| FZ □ 2050 | 20 | 50 | | | 8 | 96 | | 5.75 |
| FZ □ 2060 | | 60 | | | 10 | 120 | | 5.25 |
| FZ □ 2250 | 22 | 50 | | 14 | 8 | 112 | | 5.75 |
| FZ □ 2260 | | 60 | | | 10 | 140 | | 5.25 |
| FZ □ 2360 | 23 | 60 | | | 10 | 140 | 5.25 | |
| FZ □ 2475 | 24 | 75 | | 16 | 13 | 208 | 5.45 | 4.80 |
| FZ □ 2550 | 25 | 50 | | | 8 | 128 | 5.5 | 5.75 |
| FZ □ 2560 | | 60 | | | 10 | 160 | 5.25 | |
| FZ □ 2775 | 27 | 75 | | | 13 | 208 | 5.45 | 4.80 |
| FZ □ 2860 | 28 | 60 | | 4 | 14 | 8 | 112 | 6.5 |
| FZ □ 2875 | | 75 | 11 | | | 154 | 5.0 | |
| FZ □ 3060 | 30 | 60 | 8 | | | 112 | 7.25 | |
| FZ □ 3075 | | 75 | 11 | | | 154 | 5.0 | |
| FZ □ 3260 | 32 | 60 | 16 | | 8 | 128 | 7.25 | |
| FZ □ 3275 | | 75 | | | 11 | 176 | 5.0 | |
| FZ □ 3685 | 36 | 85 | | | 12 | 192 | 6.75 | |
| FZ □ 3690 | | 90 | | | 13 | 208 | 6.0 | |
| FZ □ 3870 | 38 | 70 | 5 | 16 | 8 | 128 | 8.0 | 7.0 |
| FZ □ 3890 | | 90 | | | 11 | 176 | 7.9 | 5.5 |
| FZ □ 4090 | 40 | 90 | | | 11 | 176 | | 5.5 |
| FZ □ 4590 | 45 | 90 | | 18 | 11 | 195 | 5.5 | |
| FZ □ 45110 | | 110 | | | 13 | 234 | 8.0 | 7.0 |
| FZ □ 5090 | 50 | 90 | | 20 | 11 | 220 | 7.9 | 5.5 |
| FZ □ 50110 | | 110 | 13 | | 260 | 8.0 | 7.0 | |
| FZ □ 6090 | 60 | 90 | 22 | 11 | 242 | 7.9 | 5.5 | |
| FZ □ 60110 | | 110 | | 13 | 286 | 8.0 | 7.0 | |
| FZ □ 80130 | 80 | 130 | 28 | 15 | 420 | 8.0 | 9.0 | |

带卡簧密珠型钢球保持架 Retainer bearing

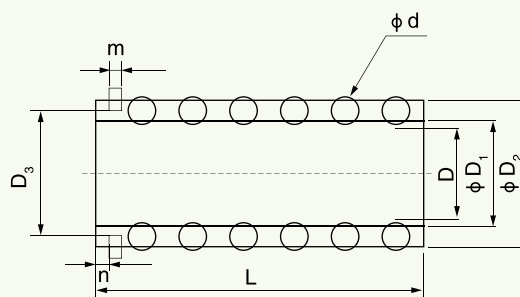

※标准产品标注方式：Standard Bushing Label Mode FZH 1848 × 3

单位Unit: mm

| D | D ₁ | D ₂ | D ₃ | d | m | n | L | 钢球数量 |
|----|----------------|----------------|----------------|-----|-----|-----|-----|------|
| 12 | 12.4 | 15.6 | 14 | 2 | 1.1 | 2.5 | 40 | 132 |
| | | | | | | | 56 | 192 |
| 12 | 12.5 | 16.5 | 15 | 2.5 | 1.1 | 2.5 | 36 | 80 |
| | | | | | | | 48 | 110 |
| | | | | | | | 60 | 140 |
| 16 | 16.5 | 21.5 | 20 | 3 | 1.3 | 2.8 | 34 | 70 |
| | | | | | | | 48 | 110 |
| | | | | | | | 63 | 150 |
| 18 | 18.5 | 23.5 | 22 | 3 | 1.3 | 2.8 | 48 | 120 |
| | | | | | | | 56 | 144 |
| | 20.5 | 25.5 | 24 | 3 | 1.3 | 2.8 | 60 | 156 |
| | | | | | | | 71 | 192 |
| 20 | 20.5 | 25.5 | 24 | 3 | 1.3 | 2.8 | 76 | 204 |
| | | | | | | | 48 | 120 |
| | | | | | | | 56 | 144 |
| 24 | 24.5 | 29.5 | 28 | 3 | 1.3 | 2.8 | 71 | 192 |
| | | | | | | | 76 | 204 |
| | | | | | | | 52 | 198 |
| 25 | 25.5 | 30.5 | 29 | 3 | 1.3 | 2.8 | 70 | 270 |
| | | | | | | | 84 | 342 |
| | | | | | | | 52 | 198 |
| 30 | 30.5 | 37.5 | 35 | 4 | 1.8 | 4.8 | 70 | 216 |
| | | | | | | | 75 | 234 |
| | | | | | | | 90 | 288 |
| | | | | | | | 95 | 306 |
| | | | | | | | 110 | 360 |
| 32 | 32.5 | 39.4 | 37 | 4 | 1.8 | 4.8 | 56 | 162 |
| | | | | | | | 75 | 234 |
| | | | | | | | 95 | 306 |
| | | | | | | | 110 | 360 |

微型滚珠衬套 Retainer bearing

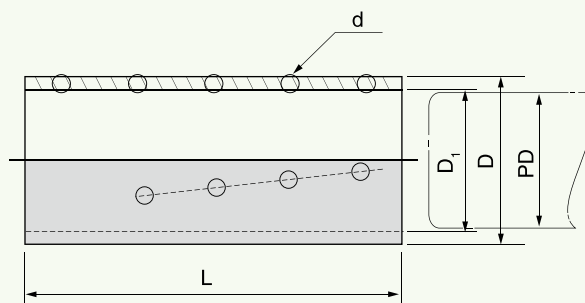

※标准产品标注方式：Standard Bushing Label Mode FZH 0815 × 1

单位Unit: mm

| 导向轴径 | 外径 ϕD | 内径 ϕD_1 | 钢球直径 ϕd | PD | L |
|------|----------------|------------------|------------------|----|----|
| 3 | 4.8 | 3.2 | 1 | 3 | 10 |
| | | | | | 15 |
| | | | | | 20 |
| 4 | 5.8 | 4.2 | 1 | 4 | 10 |
| | | | | | 15 |
| | | | | | 20 |
| 5 | 6.8 | 5.2 | 1 | 5 | 10 |
| | | | | | 15 |
| | | | | | 20 |
| 6 | 7.8 | 6.2 | 1 | 6 | 15 |
| | | | | | 20 |
| | | | | | 30 |
| 8 | 9.8 | 8.2 | 1 | 8 | 15 |
| | | | | | 20 |
| | | | | | 30 |
| 10 | 11.8 | 10.2 | 1 | 10 | 20 |
| | | | | | 30 |
| | | | | | 40 |
| 12 | 13.8 | 12.2 | 1 | 12 | 20 |
| | | | | | 30 |
| | | | | | 40 |

钢球保持架装配图

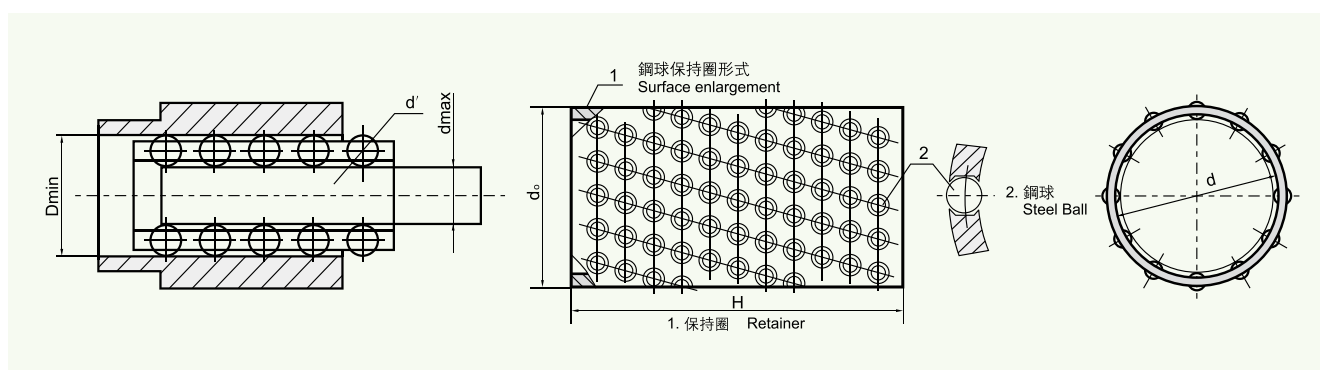



※ **通用外径检验方法 (ISO3547-2: 1999 Test B) :**

Common test method of outside diameter (ISO3547-2: 1999 Test B):

轴套用手压入环规通端 (最大用力250N) , 通过

Press the bushes into the GO ring gauge and then push them through with hand pressure

(maximum force 250N)

轴套用同样方法与同样力, 压入环规止端, 不通过

On the other hand with the same force, It shall not be possible for them to go into the

NOGO ring gauge



※ **通用的内径检验方法 (ISO3547-2: 1999 Test C) :**

Common test method of inner diameter test (ISO3547-2: 1999 Test C) :

检验内径, 轴承压入环规, 塞规通端通过用较小力, 塞规止端通不过用力最大不超过250N。

To check the inner diameter, the bush is to be press into a ring gauge. The GO plug gauge shall be inserted by a minimum effort. The NOGO Plug gauge shall not be insert by mutual pressure (maximum force 250N)

(注意: 当轴承压入环规, 轴承外径可能会被永久减小)

Note: When the bush is pressed into the ring gague, It is possible that There will be a permanent reduction in the outside diameter)



※ **通用的壁厚测量方法:**

Common methed of wall thickness measurement:

轴承的壁厚测量一点、二点、三点, 在轴向上依据轴承高度尺寸

The wall thickness is measured at one, two or three positions axially according to the bearing dimensions.

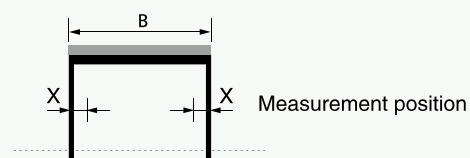

| B[mm] | X[mm] | measurement position |
|------------------|-------------|----------------------|
| $B \leq 15$ | $B/2$ | 1 |
| $15 < B \leq 50$ | 4 | 2 |
| $50 < B \leq 90$ | 6 and $B/2$ | 3 |
| $B > 90$ | 8 and $B/2$ | 3 |

轴承安装设计 Design of Bearing Arrangement

※直套 Cylindrical Bushes

座孔被倒角 $f_G \times 20^\circ \pm 5^\circ$ ，使衬套压入座孔变的更加容易。

The housing bore should have a chamfer $f_G \times 20^\circ \pm 5^\circ$, The chamfer makes it easier to press the bushes into the housing.

| 座孔直径 Housing bore diameter d_G | 座孔倒角 Chamfer of housing f_G |
|-------------------------------------|---|
| $d_G \leq 30$ | $0.8 \pm 0.3 \times 20^\circ \pm 5^\circ$ |
| $30 < d_G \leq 80$ | $1.2 \pm 0.4 \times 20^\circ \pm 5^\circ$ |
| $80 < d_G \leq 180$ | $1.8 \pm 0.8 \times 20^\circ \pm 5^\circ$ |
| $d_G > 180$ | $2.5 \pm 1.0 \times 20^\circ \pm 5^\circ$ |

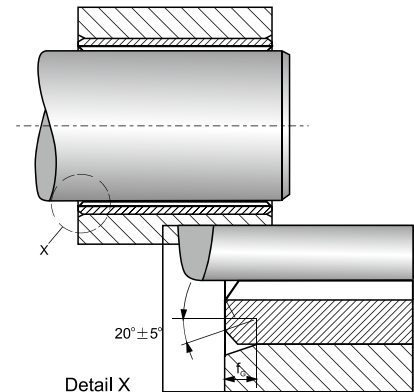

※翻边套 Flange Bushes

关于翻边套，从翻边套口到轴向转换组件必须考虑半径的转变，切面要有一个足够大的倒角。以防翻边套口聚集污垢后仍然可以支持轴向载荷部件的边缘。

The radius at the transition from the radial to the axial Component must be taken into consideration for flange bushes A sufficiently large chamfer must be provided on the housing to prevent the flanged bushes fouling in the area of the radius Sufficient support must be provided for the flange in applications With axial loading.

| 座孔直径 Housing bore diameter d_G | 座孔倒角 Chamfer of housing f_G |
|-------------------------------------|---|
| $d_G \leq 10$ | $1.2 \pm 0.2 \times 45^\circ \pm 5^\circ$ |
| $d_G > 10$ | $1.7 \pm 0.2 \times 45^\circ \pm 5^\circ$ |

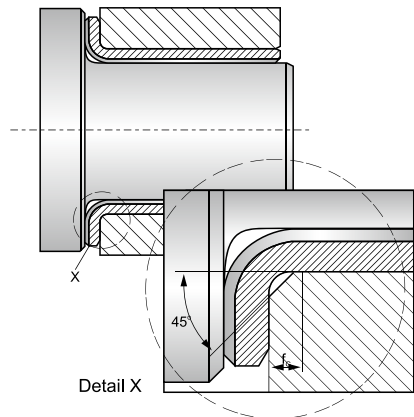

滑动轴承与座孔的装配

The installation of the sliding bushing and the housing

滑动轴承与座孔装配时，要保证轴承在座孔内不发生转动和轴向移动，又要使轴承外表面和座孔充分接触，一般应保证接触面大于85%，有利于承受载荷和传导摩擦热，采用较轻级的过盈配合，既要保证使用时，轴承不会在座孔内发生相对移动，又不会使轴承外径过盈量过大致使轴承内孔变形过大为有利于装配，轴承内外表面应涂以少量油或油脂，再将轴承均匀压入。

When installing the sliding bushing and the housing, make sure the bushing doesn't rotate or move. The outside surface of the bushing must have a through contact with the housing, in general the connecting part must be over 85%, and this will be good for the load pressure and the conduction of friction heat. Using surplus quantity loosely, that is when it is used the bushing does not move relatively and also the surplus quantity of the bushing outside diameter, will not be too big to cause serious distortion of the bushing inside hole, when installing, it is good to lay a little lubricant, such as oil on the inside and outside surface of the bushing. then press bushing slowly.

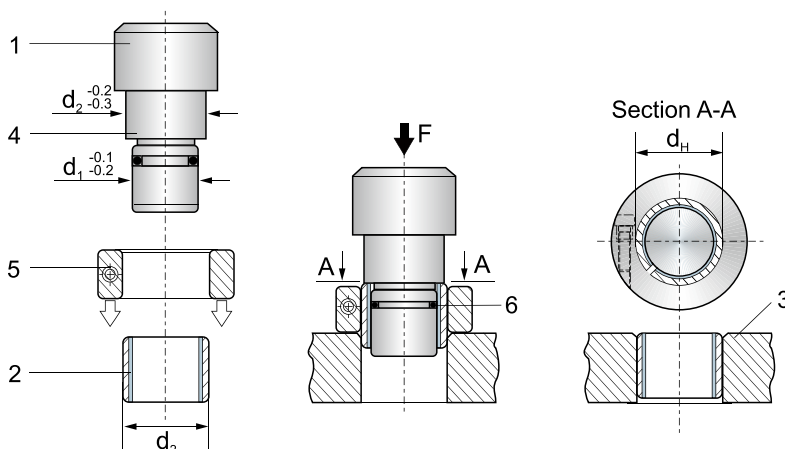

$d \geq 55\text{mm}$

1. 芯轴 Pressing-in arbor
2. 轴承 Bushes
3. 座孔 Housing
4. 档边尺寸 Shoulder diameter
5. 辅助套 Auxiliary ring
6. O型圈 O ring

| 轴承 d_2 | d_H |
|-------------|--|
| >55到100 | $d_2 \begin{matrix} +0.28 \\ +0.25 \end{matrix}$ |
| >100到200 | $d_2 \begin{matrix} +0.40 \\ +0.36 \end{matrix}$ |
| >200到305 | $d_2 \begin{matrix} +0.50 \\ +0.40 \end{matrix}$ |



浙江嘉善海丰轴承厂

JIASHAN HAIFENG BEARING FACTORY

地址: 浙江省嘉善县魏塘镇长秀路211号

邮编: 314100

电话: 0573-84161166

传真: 0573-84162567

网址: www.hfbushing.com

邮件: 404258740@qq.com

ADD: No. 211, Changxiu Rd, Weitang

Town, Jiashan, Zhejiang, China.

Post Code: 314100

TEL: +86-0573-84161166

FAX: +86-0573-84162567

Website: www.hfbushing.com

E-mail: 404258740@qq.com
